

# Mondial® Stretchers RS2, RS3, RS4



RS2 STRETCHER



RS3 STRETCHER



RS4 STRETCHER



## Ferno Customer Relations

For ordering assistance or general information:

### CANADA AND THE U.S.A.

Telephone (Toll-free)	1.877.733.0911
Telephone	1.937.382.1451
Fax (Toll-free)	1.888.388.1349
Fax	1.937.382.1191
Internet	www.ferno.com

### ALL OTHER LOCATIONS

For assistance or information, please contact your Ferno distributor. If you do not have a Ferno distributor, please contact Ferno Customer Relations:

Ferno-Washington, Inc., 70 Weil Way  
Wilmington, Ohio 45177-9371, U.S.A.

Telephone	Country Code +1.937.382.1451
Fax	Country Code +1.937.382.6569
Internet	www.ferno.com



### USERS' MANUALS

To request additional free users' manuals, contact Ferno Customer Relations, your Ferno distributor, or [www.ferno.com](http://www.ferno.com).



Serial Number \_\_\_\_\_

Location: Stretcher Head-End Crosstube

## Disclaimer

This manual contains general instructions for the use, operation and care of this product. The instructions are not all-inclusive. Safe and proper use of this product is solely at the discretion of the user. Safety information is included as a service to the user. All other safety measures taken by the user should be within and under consideration of applicable regulations and local protocol. Training on the proper use of this product must be provided before using this product in an actual situation.

Retain this manual for future reference. Include it with the product in the event of transfer to new users. Additional free copies are available upon request from Customer Relations.

## Proprietary Notice

The information disclosed in this manual is the property of Ferno-Washington, Inc., Wilmington, Ohio, USA. Ferno-Washington, Inc. reserves all intellectual property rights, proprietary design rights, manufacturing rights, reproduction use rights, and sales use rights thereto, and to any article disclosed therein except to the extent those rights are expressly granted to others or where not applicable to vendor proprietary parts.

## Limited Warranty Statement

The products sold by Ferno are covered by a limited warranty, which is printed on all Ferno invoices. The complete terms and conditions of the limited warranty, and the limitations of liability and disclaimers, are also available upon request by calling Ferno at 1.800.733.3766 or 1.937.382.1451.



Ferno-Washington, Inc.  
70 Weil Way  
Wilmington, Ohio 45177-9371, U.S.A.  
1.937.382.1451



FERNO S.r.l.  
via B. Zallone, n. 26, 40066  
Pieve di Cento, Bologna, Italy  
+39.051.6860028 234-3468-02

# TABLE OF CONTENTS

Section	Page	Section	Page
Ferno Customer Relations _____	2	5.7 Fold-Down Sidearms (Optional, RS2, RS3) _____	15
<b>1 - Safety Information</b> _____	<b>4</b>	5.8 Shock Frame (RS2, RS3) _____	16
1.1 Warning _____	4	5.9 Stationary Footrest (RS2) _____	17
1.2 Important _____	4	5.10 Pivoting Footrest (RS3, RS4) _____	18
1.3 Bloodborne Disease Notice _____	4	5.11 Lifting Rings (RS3, RS4) _____	18
1.4 Safety and Instruction Labels _____	4	5.12 Storage Tray (Optional) _____	18
1.5 Symbol Glossary _____	5	<b>6 - Using the Stretcher</b> _____	<b>19</b>
<b>2 - Operator Skills and Training</b> _____	<b>6</b>	6.1 Before Placing the Stretcher in Service _____	19
2.1 Skills _____	6	6.2 General Guidelines for Use _____	19
2.2 Training _____	6	6.3 Attaching and Removing A Stretcher _____	20
2.3 Height and Strength Considerations _____	6	6.4 Transferring the Patient _____	21
<b>3 - About the Stretcher</b> _____	<b>7</b>	6.5 Using Additional Help _____	22
3.1 Description _____	7	<b>7 - Maintenance</b> _____	<b>23</b>
3.2 CE Compliance _____	7	7.1 Maintenance Schedule _____	23
3.3 Stretcher Components _____	8	7.2 Disinfecting and Cleaning the Restraints _____	23
3.4 General Specifications _____	9	7.3 Disinfecting and Cleaning the Mattress _____	23
3.5 Load Limits _____	9	7.4 Disinfecting the Stretcher _____	23
<b>4 - Patient Restraints</b> _____	<b>10</b>	7.5 Cleaning the Stretcher _____	23
4.1 Patient Restraints _____	10	7.6 Waxing the Stretcher _____	24
4.2 Preparing the Shoulder Straps _____	10	7.7 Inspecting the Stretcher _____	24
4.3 Attaching the Torso Restraint _____	11	7.8 Lubricating the Stretcher _____	25
4.4 Attaching the Pelvis and Leg Restraints _____	12	<b>8 - Parts and Service</b> _____	<b>26</b>
<b>5 - Using the Features</b> _____	<b>13</b>	8.1 Worldwide _____	26
5.1 Side Telescoping Handles _____	13	8.2 Parts List _____	26
5.2 End Telescoping Handles (RS2) _____	13	<b>9 - Accessories</b> _____	<b>27</b>
5.3 Backrest _____	14	<b>Training Record</b> _____	<b>28</b>
5.4 Backrest Airway Management Frame (Optional) _____	14	<b>Maintenance Record</b> _____	<b>30</b>
5.5 Extending Headrest (Optional) _____	14		
5.6 Swing-Down Sidearms (RS2, RS3) _____	15		

# 1 - SAFETY INFORMATION

## 1.1 Warning

Warning safety alerts indicate a potentially hazardous situation that, if not avoided, could result in injury or death.

**WARNING**

**Untrained operators can cause injury or be injured. Permit only trained personnel to operate the stretcher.**

**Improper use of the stretcher can cause injury. Use the stretcher only for the purpose described in this manual.**

**Improper operation can cause injury. Operate the stretcher only as described in this manual.**

**An unattended patient can be injured. Stay with the patient at all times.**

**An unrestrained patient can fall off the stretcher and be injured. Use restraints to secure the patient on the stretcher.**

**An improperly-secured stretcher can separate from the transporter and cause injury. Attach the stretcher securely and verify that the slam latches have locked.**

**Helpers can cause injury. Maintain control of the stretcher, operate the controls, and direct all helpers.**

**Helpers can be injured. Show helpers where to grasp the stretcher to avoid pinch points.**

**Improper maintenance can cause injury. Maintain the stretcher only as described in this manual.**

**Improper parts and service can cause injury. Use only Ferno parts and Ferno-approved service on the stretcher.**

**Modifying the stretcher can cause injury and damage. Use the stretcher only as designed by Ferno.**

**Attaching improper items to the stretcher can cause injury. Use only Ferno-approved items on the stretcher.**

## 1.2 Important

Important notices emphasize important usage or maintenance information.

### Important

## 1.3 Bloodborne Disease Notice

To reduce the risk of exposure to blood or other potentially infectious materials when using the stretcher, follow the disinfecting and cleaning instructions in this manual.

## 1.4 Safety and Instruction Labels

Safety and instruction labels place important information from the users' manual on the stretcher. Read and follow label instructions. Replace worn or damaged labels immediately. New labels are available from your Ferno distributor (page 2).



**Load Limit Label:** Affixed to the main frame under the sidearm.



**Pinch Point Label (2):** Affixed to the main frame where the backrest rotates near the frame.

## 1.5 Symbol Glossary

The symbols defined at right are used on the stretcher and/or in this users' manual. Ferno uses symbols recognized by the International Standards Organization (ISO), American National Standards Institute (ANSI) and the emergency medical services industry.



General Warning of Potential Injury



Pinch Point: Keep Hands Clear



Read the Users' Manual



Operation Requires Two Trained Operators



Load Capacity  
(Safe Working Load in pounds, kilograms, stone)



Product meets European Union Standards



Unlocked



Locked



Do Not Lubricate



Lubricate



Manufacturer

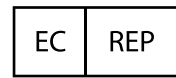

Authorized Representative in the European Community

## 2 - OPERATOR SKILLS AND TRAINING

### 2.1 Skills

Operators using the stretcher need:

- a working knowledge of emergency patient-handling procedures.
- the ability to assist the patient.

### 2.2 Training

Operator trainees need to:

- read and understand this manual and the manuals for the transporter and fastener to be used with the stretcher.
- be trained on the use of the stretcher, transporter, and fastener.
- practice with the stretcher before using it with a patient.
- record their training information. A sample training record sheet is provided on page 28.

 <b>WARNING</b>
<b>Untrained operators can cause injury or be injured. Permit only trained personnel to operate the stretcher.</b>

### 2.3 Height and Strength Considerations

Operators must be able to lift and hold the weight of the stretcher, patient and equipment high enough to load the stretcher onto the transporter at any bed height.

Supporting this weight requires greater strength from short operators than from tall operators because short operators must raise their arms higher in relation to their shoulders.

**Note:** Use additional help as needed to lift the weight of the stretcher, patient and equipment (see Using Additional Help, page 22).

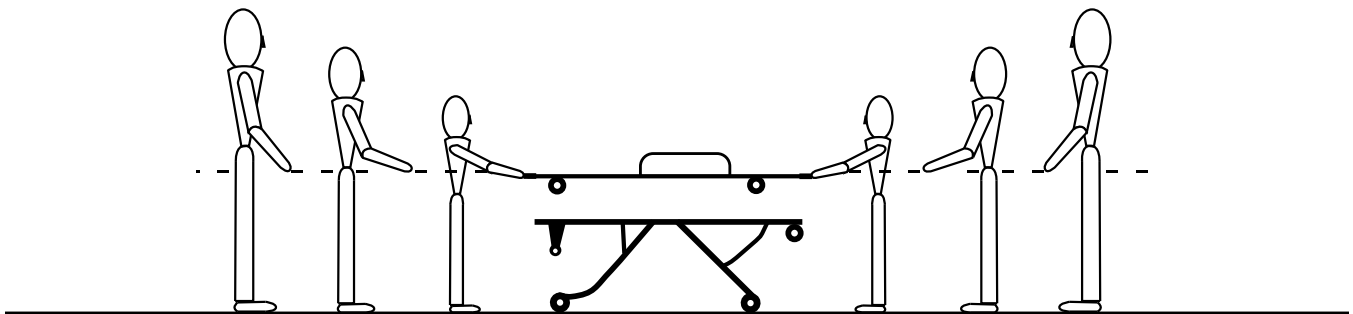

## 3 - ABOUT THE STRETCHER

### 3.1 Description

The Models RS2, RS3 and RS4 Mondial® Series Stretchers are emergency patient-handling devices. Each stretcher in the series is for professional use by a minimum of two trained operators. The stretcher can be carried by the operators or attached to a compatible transporter for wheeled transport.

In this manual, the generic term “stretcher” is used when the feature is shared by all models in the series. The individual stretcher name is used when features differ.

The stretchers are part of a three-component patient-handling system when matched with a compatible transporter and ambulance-mounted fastener.



#### WARNING

**Improper use of the stretcher can cause injury. Use the stretcher only for the purpose described in this manual.**

#### COMPATIBLE TRANSPORTERS

- Ferno® Mondial® ST64 Transporter
- Ferno® Mondial® ST70 Transporter

#### COMPATIBLE FASTENERS

- See the transporter users' manual

#### STRETCHER FEATURES

- Clear anodized handling surfaces help keep hands and clothes clean.
- Pneumatic backrest
- 4 Wheels (4 in./100 mm)
- 2 Telescoping side handles
- 4 Telescoping carrying handles (RS2)
- 3-Position shock frame with contour feature (RS2, RS3)
- Swing-down sidearms (RS2, RS3)
- 4 Integrated lifting rings (RS3, RS4)
- Stationary footrest (RS2)
- Pivoting footrest (RS3, RS4)
- (Optional) Fold-down sidearms (RS2)
- (Optional) storage tray
- (Optional) extending headrest
- (Optional) airway-management frame
- (Optional) flat or bolster mattress included (a mattress may also be purchased separately)

#### INCLUDED WITH PURCHASE

- Set of three patient restraints: one harness torso restraint and two, one-piece belt restraints
- Users' manual

### 3.2 CE Compliance

#### MEDICAL DEVICE DIRECTIVE

Ferno products meet the requirements of Medical Device Directive 93/42/EEC as established by the European Union.



#### CERTIFICATION

The Mondial® RS2, RS3 and RS4 stretchers, when used with a Ferno® Mondial® transporter plus a Ferno® FL1 or EFX-Lock fastener meet European Harmonized Standards.

Mondial® series products were independently tested by TÜV Rheinland, Germany, and certified compliant with EN 1865:1999, governing patient transport equipment, and EN 1789:2007, governing road ambulances.



#### U.S.A. NOTICE

The stretchers with approved transporters are for use with ambulances that meet the requirements of the “Star of Life” certification via Federal Ambulance Specification KKK-A-1822. For information, contact:

Federal Supply Services, Specifications Section  
Suite 8100  
470 E. L'Enfant Plaza, SW  
Washington, DC 20407



### 3.3 Stretcher Components

#### RS2 STRETCHER

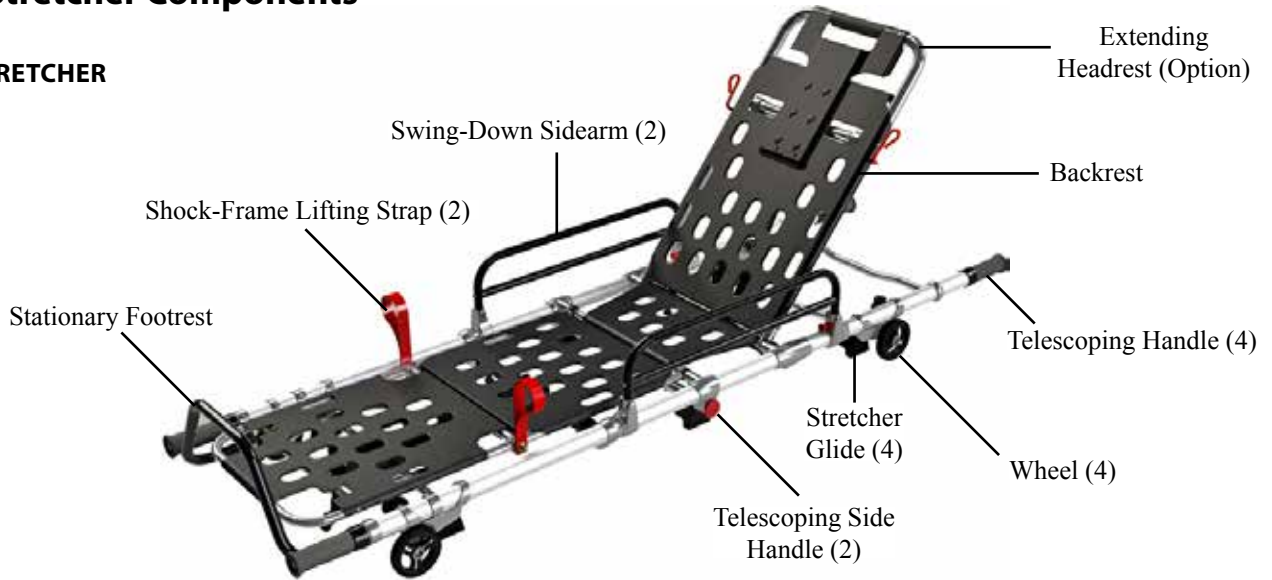

#### RS3 STRETCHER

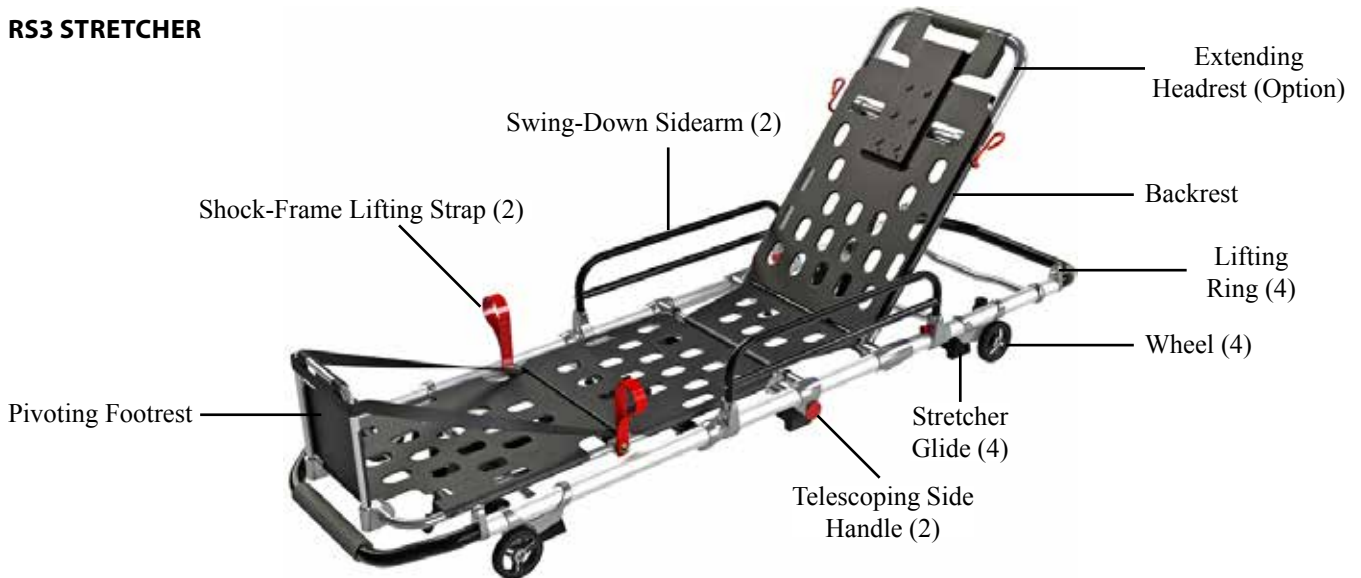

#### RS4 STRETCHER

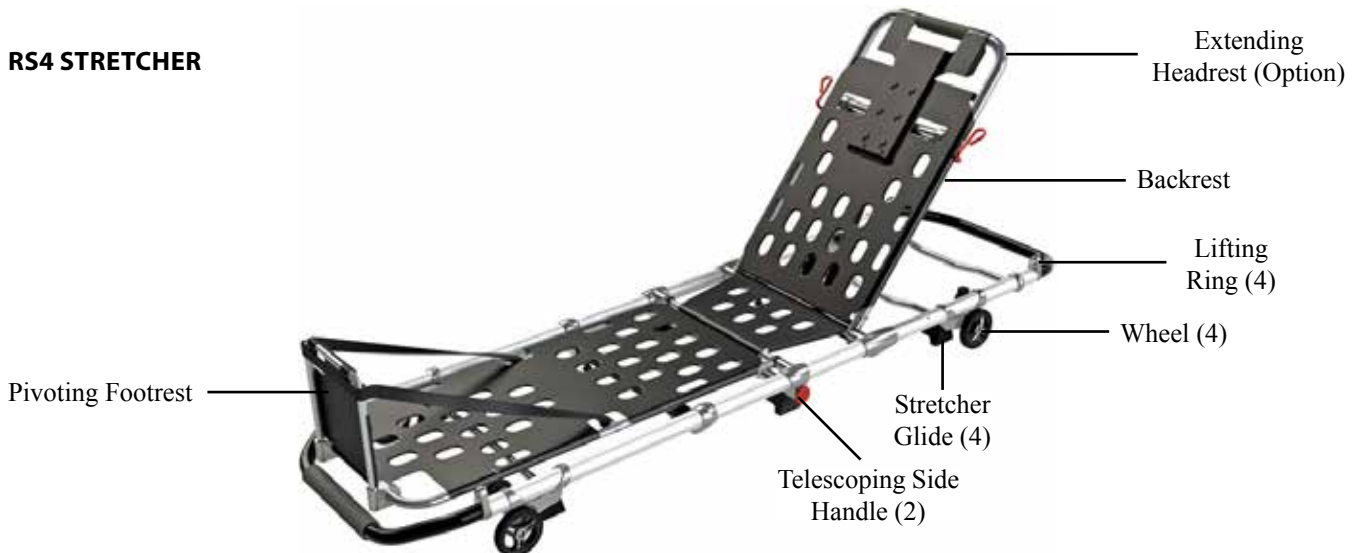



### 3.4 General Specifications

Most general specifications are rounded to the nearest whole number. Metric conversions are calculated before rounding the Imperial measurements. For more information, contact Ferno Customer Relations (page 2) or your Ferno distributor. Ferno reserves the right to change specifications without notice.

<b>Construction</b>	Tubular aluminum	
<b>Bed Surface</b>	Aluminum panels	
<b>Wheels</b>		
Diameter	4 in.	100 mm
Width	0.75 in.	19 mm
<b>Height</b>		
Overall (RS2, RS3 top of sidearms)	12 in.	300 mm
Bed Height <sup>1</sup>	6 in.	150 mm
<b>Length</b>		
RS2 Minimum	77 in.	1950 mm
RS2 Handles Position 2	86 in.	2195 mm
RS2 Handles Position 3	96 in.	2445 mm
RS3	77 in.	1950 mm
RS4	77 in.	1950 mm
Width	22 in.	550 mm
<b>Weight<sup>2</sup></b>		
RS2	50.4 lb	22.9 kg
RS3	49.8 lb	22.6 kg
RS4	46.4 lb	21 kg
<b>Load Limit</b>	<b>500 lb</b>	<b>230 kg</b>

**Note:** All Ferno® mattresses for emergency medical service use are heat-sealed.

<sup>1</sup>Bed Height is the distance from the ground to the patient surface at the telescoping handle.

<sup>2</sup>Weight is without mattress, restraints and optional features.

### 3.5 Load Limits

Each model of stretcher and transporter has a specific load limit. When pairing a stretcher and transporter, do not exceed the load limit of either component.



**Stretcher Load Limit**

Inspect the stretcher if the load limit has been exceeded. See *Inspecting the Stretcher*, page 24.



**Mondial® Transporter Load Limit (Reference)**

The transporter is designed to carry the maximum load of a stretcher, plus the weight of the stretcher. Do not exceed product load limits.

## 4 - PATIENT RESTRAINTS

### 4.1 Patient Restraints

A set of three patient restraints is supplied (Figure 1): a harness restraint for use at the patient's shoulders and chest; a 2134 mm (7-foot), one-piece restraint for use at the patient's pelvis; and a 1524 mm (5 foot), one-piece restraint for use with the patient's upper or lower legs.

Use all three restraints to secure the patient on the stretcher. Adjust restraints to safely secure the patient without causing discomfort or impairing circulation. Position restraints so they will cross bony structures of the body, such as the ribs, pelvis, and upper- or lower-leg bones.

Keep restraints fastened when not in use to prevent them from interfering with stretcher or transporter operation.

For complete usage and maintenance information, see the restraint users' manuals (provided).

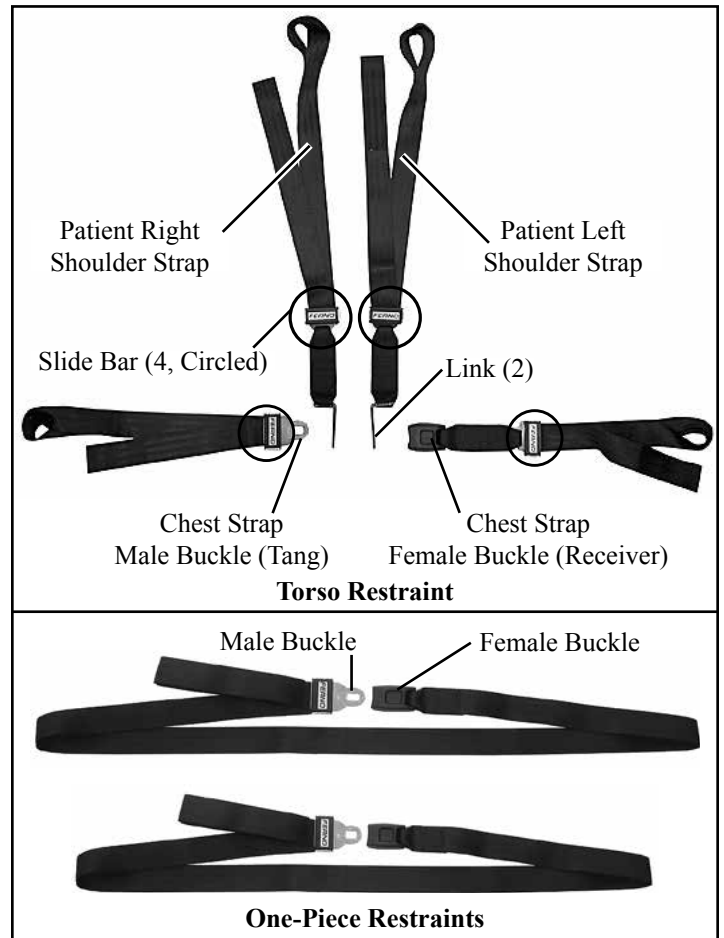

Figure 1 - Patient Restraints

### 4.2 Preparing the Shoulder Straps

1. Raise the backrest.
2. Use a flat-blade screwdriver to pry the plastic covers off the two shoulder strap link sliders (Figure 2).



Figure 2 - Removing the Plastic Cover

## 4.3 Attaching the Torso Restraint

### ATTACHING THE SHOULDER STRAPS

**Note:** When attaching shoulder straps, verify that the links will be touching (facing the center of the backrest) when attached. See the orientation of the links in Figure 1, page 10.

1. Wrap the looped end of a shoulder strap around the stretcher main-frame crosstube, located at the bottom of the backrest (Figure 3).

2. Insert the link through the loop and pull the strap through the loop until the strap is tight around the crosstube.
3. Route the link end of the strap over the backrest control crosstube and through the backrest (Figure 4 and Figure 5). Verify that the strap will not interfere with the function of the backrest control handle.
4. Press the plastic cover onto the slider (Figure 6).
5. Repeat Steps 1-4 to attach the other shoulder strap.

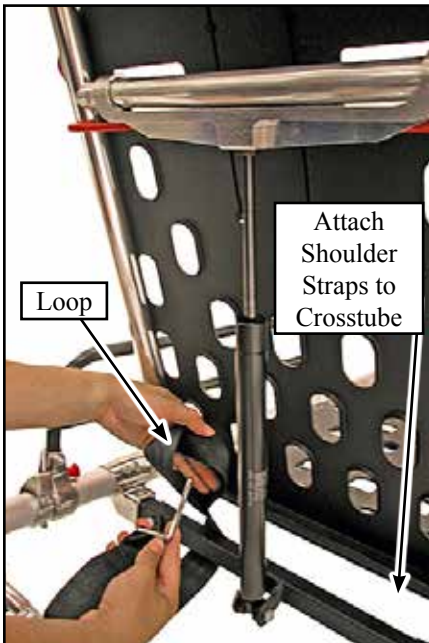

**Figure 3 - Insert Link-End Through Loop**



**Figure 4 - Route Link Over Crosstube and Through Backrest**

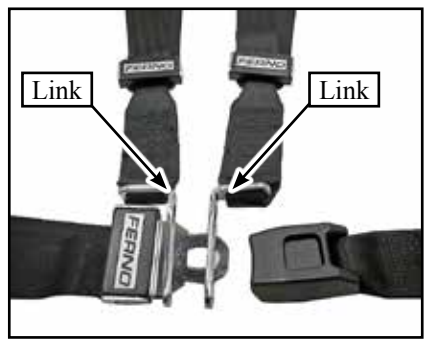

**Figure 5 - Link On Patient Surface Side of Backrest**

### Important

When attaching the shoulder straps, orient the links so they touch when the buckle is assembled.

Insert the male buckle (tang) through both shoulder-strap links and into the female buckle (receiver) until it locks into place.



**Figure 6 - Attach Cover**

## ATTACHING THE CHEST STRAPS

1. There are two pairs of restraint slots on the backrest frame. Select either the upper or lower pair of slots; attach the chest straps only to a matched set of slots (Figure 7).
2. Wrap the looped end of a chest strap around the backrest frame.
3. Slide the male (or female) end of the strap through the loop (Figure 7). Pull the strap through the loop until the strap is tight around the backrest frame.
4. Repeat Steps 2 and 3 to attach the other half of the chest strap to a matching slot on the opposite side of the backrest frame.

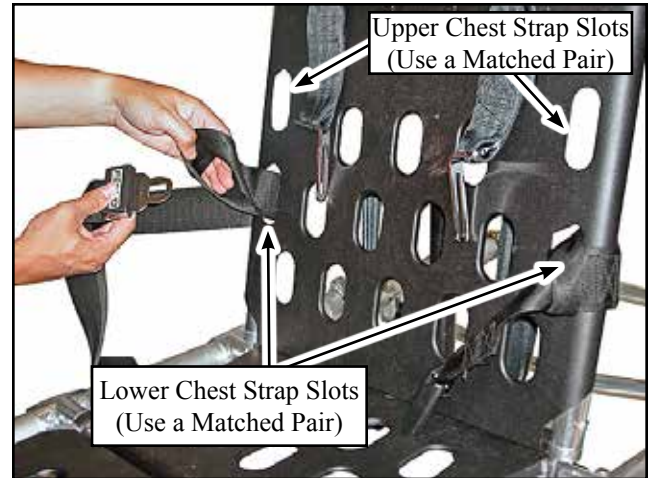

**Figure 7 - Attaching the Chest Strap Slots**

## 4.4 Attaching the Pelvis and Leg Restraints

### ATTACHING THE PELVIS RESTRAINT

Lay the 2134 mm/7-foot restraint for the pelvis across the top surface of the seat panel and wrap the ends of the restraint around the main frame (Figure 8).

### ATTACHING THE LEG RESTRAINT

- Follow your local protocols to select the appropriate restraint position using the pair of slots in either the upper or lower shock frame panel (Figure 9).
- Feed the male end of the 1524 mm (5 foot) restraint upward through one slot in the shock frame panel, across the top surface of the panel, and through the opposite slot.
- Wrap the restraint around the patient surface only. Do not wrap this restraint around the stretcher main frame.
- Verify that the restraint placement does not interfere with using the shock frame.



**Figure 8 - Pelvis Restraint Properly Attached**

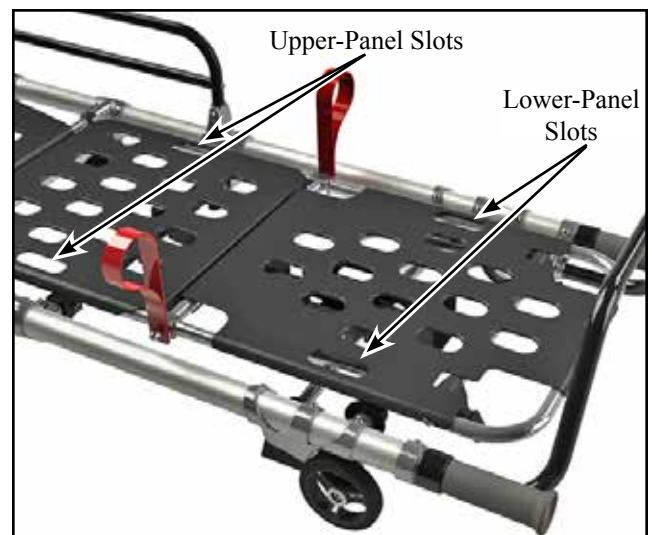

**Figure 9 - Leg-Restraint Slots**



## 5 - USING THE FEATURES

### 5.1 Side Telescoping Handles

- **Purpose:** Operators or helpers use the side telescoping handles as extra lifting or grasping points.
- **Use:** Pull to extend the handle; push to retract (Figure 10). When lifting, balance the stretcher by placing one operator or helper on each side of the stretcher and lift together, using both handles.
- Grasping positions:
  - With one hand, grasp the stretcher main frame using an underhand grasp. With your other hand, grasp the handle using a cylindrical grip; OR
  - Grasp the handle with both hands.



Figure 10 - Side Telescoping Handle

### 5.2 End Telescoping Handles (RS2)

- **Purpose:** A pair of telescoping handles is located at each end of the stretcher. The operators extend and use the handles to lift and carry the stretcher. The handles lock in three positions (Figure 11):
  - Fully retracted
  - Middle (about 5 in./125 mm)
  - Fully extended (about 10 in./255 mm)
- **Use:** To change the handle position, press the button on the end of the handle (Figure 12) and push or pull the handle to the desired position. Release the button and pull or push the handle until it locks.

Use the telescoping handles only when they are in a locked position.

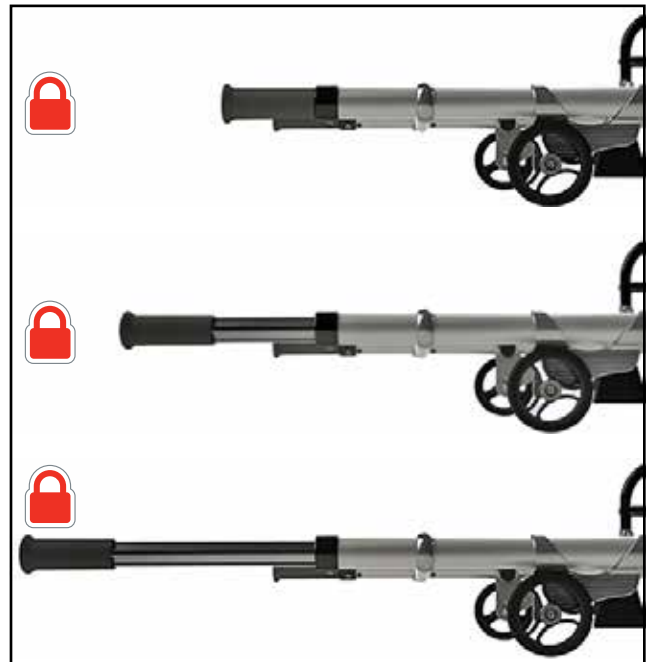

Figure 11 - Lift Handle Positions



Figure 12 - Telescoping Handle Release Button

## 5.3 Backrest

- **Purpose:** The backrest allows the operator to elevate the patient's torso for patient comfort or medical necessity
- **Before Use:**
  - Loosen or unbuckle the torso restraint.
  - Support the weight of the backrest and patient.
- **Use:** Press one of the red backrest-control handles down (toward the main frame, Figure 13) to unlock the backrest, then raise or lower the backrest to the desired position. Release the control handle to lock the backrest at the new position.

The gas spring is under pressure to ease raising and lowering. When a heavy patient is on the stretcher, support the patient's weight before adjusting the backrest. When a light patient is on the stretcher, control the upward movement of the backrest so it does not move too quickly.

- **After Use:** Buckle and adjust the torso restraint.



Figure 13 - Backrest Control Handle

## 5.4 Backrest Airway Management Frame (Optional)

- **Purpose:** The airway management frame allows the head section of the backrest to be adjusted between three locking positions to allow trained medical personnel to access and work with the patient's airway.
- **Use:** To adjust the frame, pull the release bar (Figure 14), and rotate the frame to the new position. Let go of the bar to allow the frame to lock.

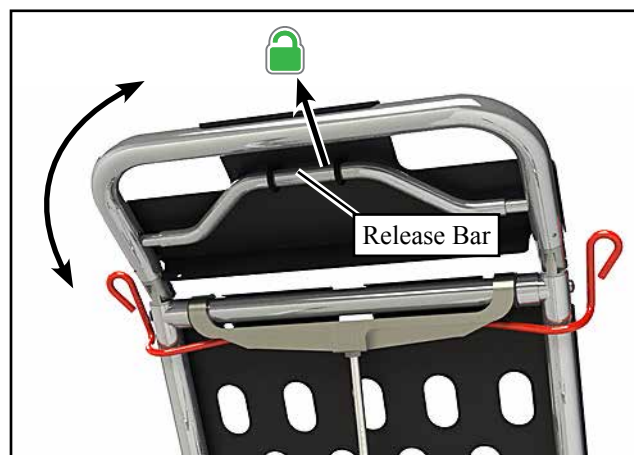

Figure 14 - Airway Management Control Handle

## 5.5 Extending Headrest (Optional)

- **Purpose:** Use the extending headrest to make the patient surface longer for a tall patient. This feature extends the patient surface by 7 in./180 mm.
- **Use:** To extend the headrest, pull the frame until it stops at the extended position (Figure 15). To retract, push the frame in until it stops.



Figure 15 - Extending Headrest

## 5.6 Swing-Down Sidearms (RS2, RS3)

- **Purpose:** Sidearms provide patient security and comfort. Keep the sidearms raised except during patient transfer.
- **Use:**
  - **To lower,** pull the sidearm release pin (Figure 16) and swing the sidearm down.
  - **To raise,** rotate the sidearm upward until it locks.

### Important

Do not use the sidearms to lift the stretcher. Sidearms are not designed for lifting. Lift the stretcher only by grasping the main frame, or main frame and telescoping side handles.

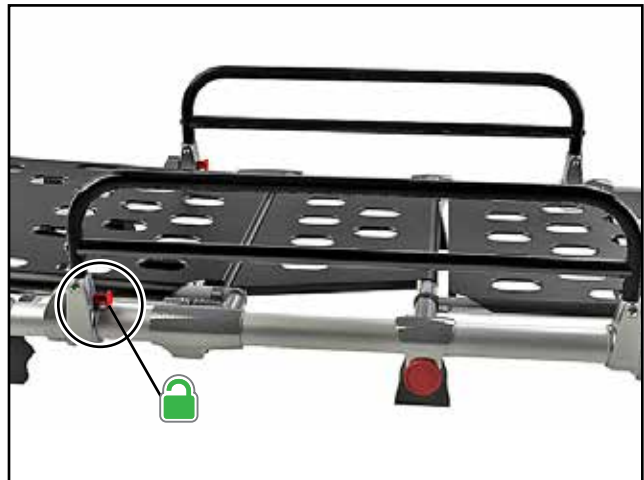

Figure 16 - Sidearm Release Pin

## 5.7 Fold-Down Sidearms (Optional, RS2, RS3)

- **Purpose:** Sidearms provide patient security and comfort. Keep the sidearms raised except during patient transfer.
- **Use:**
  - **To lower,** Squeeze the sidearm release handle (Figure 17) and fold the sidearm (Figure 18).
  - **To raise,** lift the sidearm upward until it locks.

### Important

Do not use the sidearms to lift the stretcher. Sidearms are not designed for lifting. Lift the stretcher only by grasping the main frame, or main frame and telescoping side handles.



Figure 17 - Fold-Down Sidearm



Figure 18 - Sidearm Folded



### 5.8 Shock Frame (RS2, RS3)

In addition to the flat position, the shock frame adjusts to two raised positions:

- **Raised shock** (Modified Trendelenburg position, Figure 19)
- **Contour shock** (Fowler's position, Figure 21, page 17)

Follow your local medical protocols when deciding which position to use. Use an underhand grip (palms up) to support the shock frame while raising or lowering it.

#### RAISED SHOCK POSITION

Use the raised or Modified Trendelenburg shock position to elevate the patient's legs. To raise the shock frame:

1. Unfasten or loosen the leg restraint.
2. From the foot end of the stretcher, lift the shock frame with both hands until it locks in the raised position (Figure 19). The support bars will engage automatically.
3. Fasten and adjust the leg restraint.

To lower the shock frame:

1. Unfasten or loosen the leg restraint.
2. From the foot end of the stretcher, support the weight of the shock frame with both hands and lift slightly.
3. With your thumbs, press the shock frame control levers to disengage the support bars (Figure 20), then lower the shock frame.
4. Fasten and adjust the leg restraint.

#### CONTOUR SHOCK POSITION

Use the contour or Fowler's shock position to elevate the patient's knees higher than the feet. To raise the shock frame:

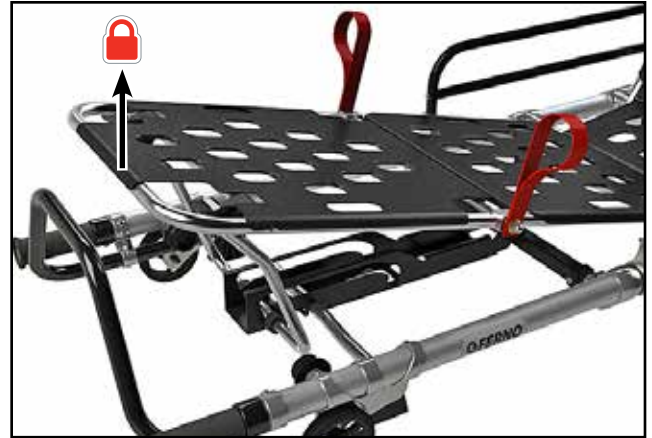

Figure 19 - Raised Shock Position



Figure 20 - Lowering the Shock Frame

## Using the Features

1. Unfasten or loosen the leg and pelvis restraints.
2. Grasp the lifting strap with one hand and the foot end of the shock frame with your other hand.
3. Lift the shock frame with the lifting strap while sliding the foot end of the shock frame toward the head end of the stretcher (Figure 21) until the frame locks in the contour position.
4. Fasten and adjust the restraints.

To lower the shock frame:

1. Unfasten or loosen the leg and pelvis restraints.
2. Use the lifting strap to lift the shock frame slightly.
3. With your thumb, press the shock frame control levers (Figure 22) to disengage the support bars, then lower the shock frame.
4. Fasten and adjust the restraints.

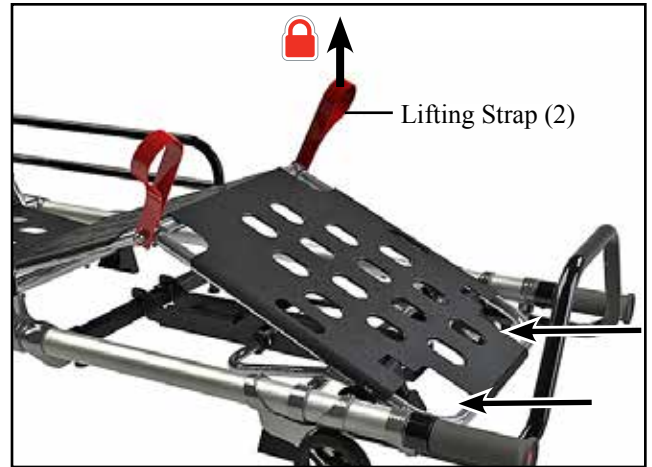

**Figure 21 - Contour Shock Frame Position**

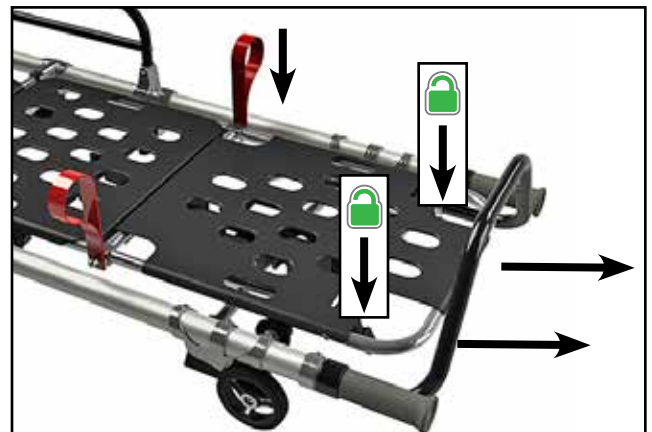

**Figure 22 - Lowering From the Contour Position**

### 5.9 Stationary Footrest (RS2)

The RS2 stretcher has a permanent, built-in footrest (Figure 23). The footrest provides stability and support for a patient's feet.



**Figure 23 - Stationary Footrest**

### 5.10 Pivoting Footrest (RS3, RS4)

- **Purpose:** The pivoting footrest provides stability and support for a patient's feet (Figure 24).
- **Use:** Swing the panel to the raised position for use. Lay the panel down to store. The panel may be stored under the mattress when not in use.

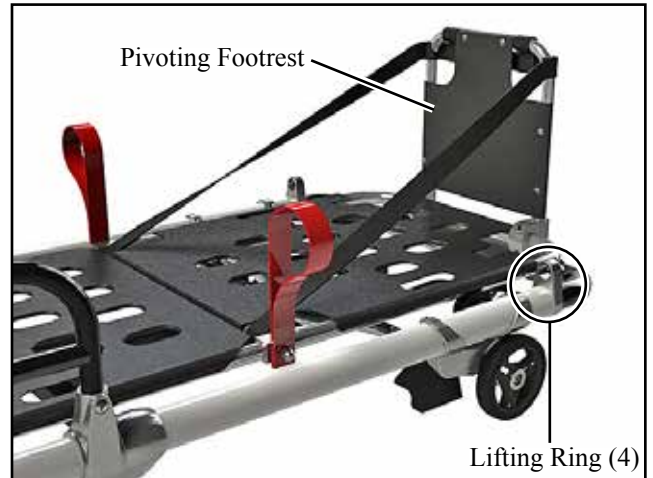

Figure 24 - Pivoting Footrest Open for Use

### 5.11 Lifting Rings (RS3, RS4)

Four lifting rings are mounted to the corners of the main frame. When lifting the stretcher using technical rescue equipment (lifting bridle, winch, etc.) attach the lifting equipment **ONLY** to the lifting rings (Figures 24 and 25).

**Note:** The lifting rings are designed to allow **ONLY** the stretcher to be lifted. They are not designed to lift the stretcher and transporter. Do not lift the stretcher when it is attached to the transporter.

Technical rescue procedures require specialized training. Undertake technical rescue procedures only with proper training. Follow the bridle manufacturer's directions for attaching and using the bridle.

Securely restrain the patient on the stretcher using all patient restraints as directed in this manual, plus additional restraints. Follow your local protocols for technical rescue.



Figure 25 - Using the Lifting Rings

### 5.12 Storage Tray (Optional)

- **Purpose:** The optional storage tray is integrated with the stretcher under the backrest (Figure 26).
- **Use:** Raise the backrest to place objects on the storage tray. Remove objects before lowering the backrest.



Figure 26 - Storage Tray

## 6 - USING THE STRETCHER

### 6.1 Before Placing the Stretcher in Service

- Personnel who will work with the stretcher need to read this manual and the users' manual for the transporter and fastener to be used with the stretcher.
- Set up the stretcher, following the instructions in Patient Restraints, pages 10-12.
- Confirm that the stretcher operates properly. See Inspecting the Stretcher, page 24.
- The vehicle must have a Ferno® fastener system installed.

### 6.2 General Guidelines for Use

- Medical advice is beyond the parameters of this manual.
- It is the users' responsibility to ensure safe practices for the patient and themselves.
- A **minimum** of two trained operators is required.
- **Operators work together and maintain control of the stretcher at all times.**
- Follow standard emergency patient-handling procedures when using the stretcher.
- Operators **must** communicate with one another and use coordinated movements to operate the stretcher.
- Operators **must** stay with the patient at all times.
- Always use patient restraints to secure the patient on the stretcher.
- Select appropriate restraints for the patient being transported. A list of Ferno patient restraint systems compatible with the stretcher is at right.
- Lift only the weight you can safely handle. Use additional help when working with heavy loads (patient and equipment). For placement of helpers, see Using Additional Help, page 22.

**Note:** The transporter is designed to carry the maximum load of a stretcher plus the weight of the stretcher. Do not exceed the stretcher load limit.

#### WARNING

Improper operation can cause injury. Operate the stretcher only as described in this manual.

#### WARNING

An unattended patient can be injured. Stay with the patient at all times.

#### WARNING

An unrestrained patient can fall off the stretcher and be injured. Use restraints to secure the patient on the stretcher.



Read the Users' Manual



Operation Requires  
Two Trained Operators



### Stretcher Load Limit

Inspect the stretcher if the load limit has been exceeded. See *Inspecting the Stretcher*, page 24.

#### Ferno Patient Restraint Systems (Not Supplied)

Ferno Product	Metric Patient Weight	Imperial Patient Weight
Model 678 Pedi-Mate®	4.5-18.1 kg	10-40 lb
RS2, RS3, RS4 Restraint, Harness	Up to Rated Load Capacity	
Restraint, Model 430 2-piece, 1.5m [5']	Up to Rated Load Capacity	
Restraint, Model 430 1-piece, 2.1m [7']	Up to Rated Load Capacity	

\*Follow local protocols for selection and application of patient restraints. See "Accessories" on page 27.



## 6.3 Attaching and Removing A Stretcher

The stretcher can be locked onto a transporter with the patient's head at either end of the transporter.

A stretcher locks onto the transporter when the strike pins on the bottom of the stretcher engage the transporter slam latches (Figure 27).

**Note:** Mondial® stretchers are compatible only with Ferno® Mondial® series transporters.

### ATTACHING THE STRETCHER

1. Lock the transporter wheel locks to help hold the transporter stationary.
2. **Both Operators:** Lift the stretcher and position the stretcher slightly toward the control end of the transporter (Figure 28). Use additional help as needed to control the load (see *Using Additional Help*, page 22).
3. **Both Operators:** Align the stretcher glides with the transporter main frame and set the stretcher on the transporter main frame.
4. **Both Operators:** Roll the stretcher toward the loading end of the transporter until the stretcher strike pins fully engage in the transporter slam latches.

**Note:** For patient safety, both operators must maintain their grasp on the stretcher until it is securely locked onto the transporter.

5. **Control-End Operator:** Verify that the stretcher is locked by attempting to pull it toward the control end of the transporter. If the locks have engaged, the stretcher will remain fixed on the transporter. If the locks have not engaged, repeat Steps 2-4.
6. **Control-End Operator:** Release the transporter wheel locks before rolling the transporter.

### REMOVING THE STRETCHER

1. **Both Operators:** As the Control Operator pushes and holds the yellow stretcher-release handle on the transporter (Figure 29), both operators move the stretcher slightly toward the control end of the transporter to move the strike pins out of the slam latches.
2. **Control-End Operator:** Let go of the stretcher-release handle when the stretcher has cleared the strike pins.
3. **Both Operators:** Together, lift the stretcher off the transporter. Use additional help as needed to control the load (see *Using Additional Help*, page 22).

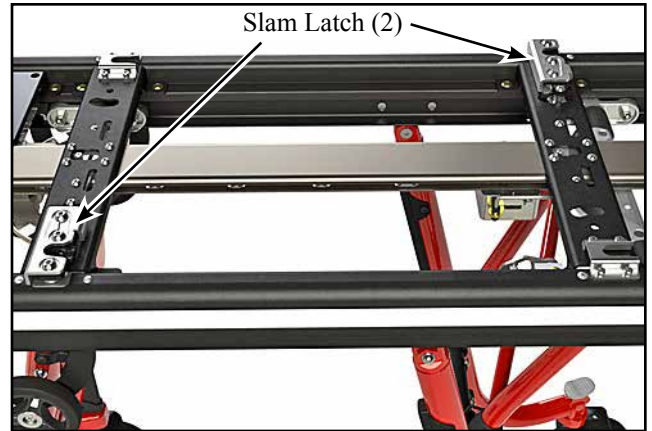

Figure 27 - Slam Latches on Transporter

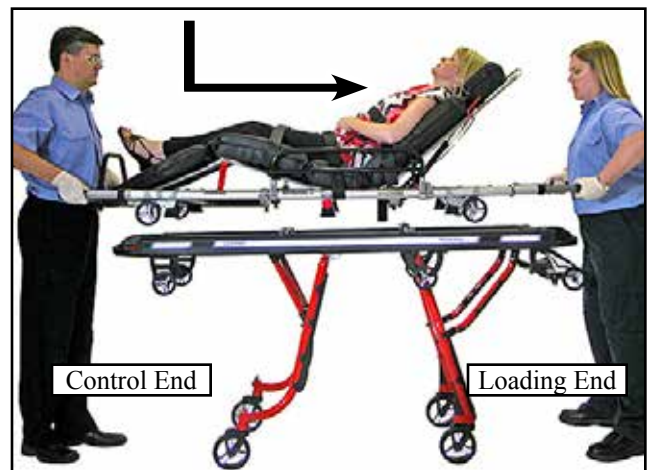

Figure 28 - Attaching the Stretcher

**⚠ WARNING**

**An improperly-secured stretcher can separate from the transporter and cause injury. Attach the stretcher securely and verify that the slam latches have locked.**



Figure 29 - Stretcher-Release Handle

### 6.4 Transferring the Patient

To minimize lifting and moving, place the stretcher (or transporter with stretcher attached) as close as possible to the patient. Follow your local protocols and the instructions below. Use additional help as needed (see *Using Additional Help*, page 22).

#### TRANSFER TO STRETCHER

This transfer procedure is recommended when the patient is on the floor or ground, or when the patient location cannot be accessed by the transporter. Follow your local protocols for patient transfer.

1. Lock the transporter wheel locks to help hold the transporter steady when you reattach the stretcher later.
2. Remove the stretcher from the transporter and place it near the patient.
3. Lower the sidearms (if equipped).
4. Unfasten the restraints and position the restraint straps so they will not interfere with transferring the patient (Figure 30).
5. Transfer the patient onto the stretcher using approved emergency medical procedures and your local protocols.
6. Raise the sidearms, adjust the backrest and/or shock frame as needed and fasten and adjust the restraints.
7. Using additional help if needed, lift and carry the stretcher and patient to the transporter.
8. Secure the stretcher on the transporter (See *Attaching and Removing A Stretcher*, page 20).
9. Unlock the transporter wheel locks before rolling the transporter.

#### TRANSFER TO TRANSPORTER

This transfer procedure is recommended when the patient is on a bed, sofa, etc. and the transporter can be placed near the patient. Follow your local protocols for patient transfer.

1. Position the transporter near the patient, lower it to the patient's level, and lock the wheel locks.
2. Lower the sidearms (if equipped), unfasten the restraints, and position the restraint straps so they will not interfere with transferring the patient.
3. Transfer the patient onto the transporter using approved emergency medical procedures and your local protocols.
4. Raise the sidearms, adjust the backrest and/or shock frame as needed and fasten and adjust the restraints.
5. Unlock the wheel locks and raise the transporter to a rolling level.



**Figure 30 - Transferring a Patient  
Onto the Stretcher**

## 6.5 Using Additional Help

Operating the stretcher requires a minimum of two trained operators. They may need additional help when working with heavy loads (patient plus equipment).

- Operators stand at the head and foot ends of the stretcher, maintain control of the stretcher, operate the controls, and direct all helpers.
- Side helpers may need to walk sideways under some circumstances. Follow local protocols.
- Ferno recommends that helpers work in pairs to help maintain stretcher balance.

The chart at right shows suggested placement for operators and helpers.



**Stretcher Load Limit**  
 Inspect the stretcher if the load limit has been exceeded. See *Inspecting the Stretcher*, page 24.

**Important**

Trained operators position themselves at the head and foot ends of the stretcher and operate the controls. Show helpers where to stand and how to grasp the stretcher.

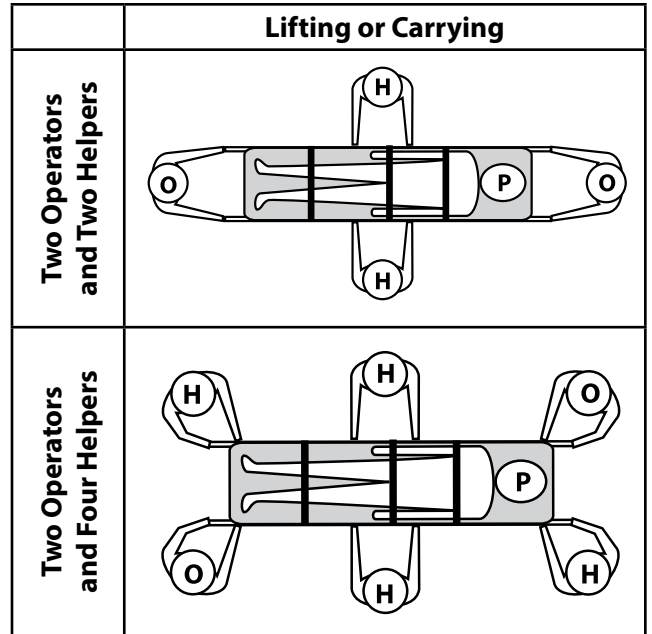

Key: O = Operator H = Helper P = Patient

**⚠ WARNING**

Helpers can cause injury. Maintain control of the stretcher, operate the controls, and direct all helpers.

**⚠ WARNING**

Helpers can be injured. Show helpers where to grasp the stretcher to avoid pinch points.



## 7 - MAINTENANCE

### 7.1 Maintenance Schedule

The stretcher requires regular maintenance. Set up and follow a maintenance schedule. The table at right represents minimum intervals for maintenance.

Keep maintenance records. A sample maintenance record sheet is provided on page 28.

When using maintenance products, follow the manufacturers' directions and read the manufacturers' material safety data sheets. You can purchase a recommended disinfectant from your Ferno distributor.

### 7.2 Disinfecting and Cleaning the Restraints

Remove the restraints from the stretcher. Disinfect and clean only as directed in the restraint users' manuals provided with the restraints. Additional, free users' manuals can be obtained from Ferno Customer Relations (page 2) or your Ferno distributor.

After cleaning and/or disinfecting, attach the clean, dry restraints as shown in *Patient Restraints*, pages 10-12.

### 7.3 Disinfecting and Cleaning the Mattress

1. Remove the mattress from the stretcher.
2. **To disinfect:** Apply disinfectant to the mattress, following the disinfectant manufacturer's instructions for application method and contact time.
3. **To clean:** Wash the mattress with warm, soapy water and a soft cloth. Rinse the mattress with clear water. Hang the mattress to dry, or dry it with a towel.

### 7.4 Disinfecting the Stretcher

Wipe all surfaces with disinfectant. Follow the disinfectant manufacturer's instructions for application method and contact time. Ferno recommends you inspect the stretcher for damage as you disinfect it.

### 7.5 Cleaning the Stretcher

1. Remove the restraints, mattress and any accessories.
2. Hand clean all surfaces of the stretcher with warm water and a mild detergent.
3. Rinse with warm, clear water. Dry the stretcher with a towel or allow it to air-dry.

 **WARNING**

**Improper maintenance can cause injury. Maintain the stretcher only as described in this manual.**

Minimum Maintenance Intervals	Each Use	As Needed	Each Month
<b>Disinfecting</b> (this page)	•		
<b>Cleaning</b> (this page)		•	
<b>Waxing</b> (page 24)		•	
<b>Inspecting</b> (page 24)		•	•
<b>Lubricating</b> (page 25)		•	

**Important**

Disinfectants and cleaners containing bleach, phenolics, or iodines can cause damage. Do not use products containing these chemicals.

**Important**

Water under high pressure, or steam, can penetrate joints, flush away lubricant, and cause corrosion. Use caution when cleaning moving parts such as joints and hinges, and reapply lubricant if needed (see page 25).

**Important**

Using abrasive cleaning compounds or applicators on the stretcher can cause damage. Do not use abrasive materials to clean the stretcher.

### 7.6 Waxing the Stretcher

While it is not necessary to wax this stretcher, waxing the aluminum main frame will not damage it, and will help maintain the stretcher's appearance.

Disinfect and clean the stretcher before applying wax. Apply an automotive wax as directed by the wax manufacturer.

### 7.7 Inspecting the Stretcher

Have your service's equipment maintenance personnel inspect the stretcher regularly. Follow the checklist at right and operate the stretcher through all its functions as described in this manual.

If inspection shows damage or excessive wear, remove the stretcher from service until repair is made. See *Parts and Service*, page 26.

#### INSPECTION CHECKLIST

- Are all components present?
- Is the stretcher free of excessive wear?
- Are all screws, nuts, bolts, roll pins and rivets securely in place?
- Do all moving parts operate smoothly and properly?
- Does the stretcher roll smoothly?
- Are the wheels free of excessive wear?
- Are optional features (telescoping head section, airway management frame, etc.) free of damage and do they function properly?
- Does the stretcher attach securely to the transporter?
- Are the restraints properly installed?
- Is restraint webbing in good condition with no cuts or frayed edges?
- Are restraint buckles free of visible damage and do they operate properly?
- Is the ambulance properly prepared for the stretcher/ transporter, with an approved Ferno® fastener installed?
- Do installed accessories operate properly without interfering with stretcher operation?

## 7.8 Lubricating the Stretcher

Disinfect and clean the stretcher before applying lubricant. Use only the designated lubricants on the stretcher. Use a small amount of lubricant and lubricate identical points on each side of the stretcher. Do not lubricate points marked with the “do not lubricate” symbol.



**Do Not Lubricate**



**Lubricate**

### Important

Lubricating parts that should not be lubricated allows dirt and foreign particles to collect on those parts, resulting in damage. Lubricate **only** the numbered reference points shown.

### LUBRICATION POINTS

- |                                    |                               |
|------------------------------------|-------------------------------|
| 1. Shock frame hinges              | WRL-191S or E-Z-1 (1-2 drops) |
| 2. Sidearm lock pins               | WRL-191S or E-Z-1 (1-2 drops) |
| 3. Telescoping handles             | WRL-191S or E-Z-1 (1-2 drops) |
| 4. Pivoting footrest hinges        | WRL-191S or E-Z-1 (1-2 drops) |
| 5. Airway management frame hinges* | WRL-191S or E-Z-1 (1-2 drops) |

\*If equipped

### LUBRICATION-FREE ITEMS

- |                          |                  |
|--------------------------|------------------|
| Telescoping side handles | Do not lubricate |
| Backrest hinges          | Do not lubricate |
| Wheels                   | Do not lubricate |
| Fold-down sidearm        | Do not lubricate |

RS2 Stretcher

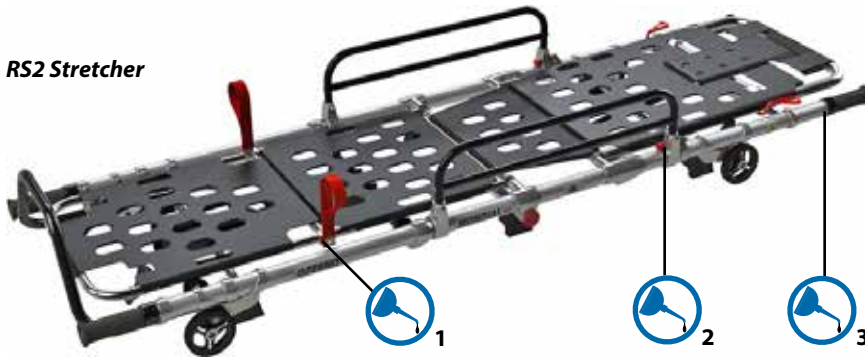

RS3 Stretcher

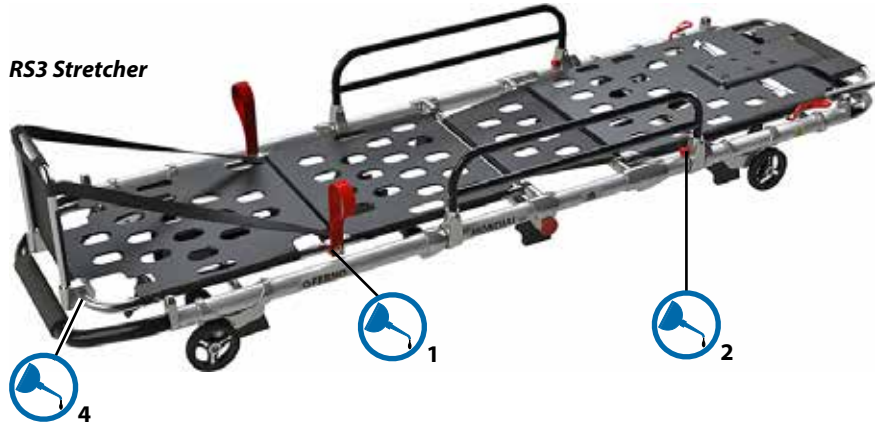

RS4 Stretcher

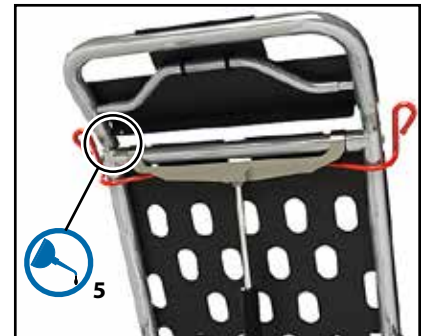

## 8 - PARTS AND SERVICE

### 8.1 Worldwide

To order Ferno parts, and for professional stretcher repair, contact your Ferno distributor. Your distributor is the only agent authorized by Ferno to manage, service, and repair Ferno products.

**⚠ WARNING**  
**Improper parts and service can cause injury. Use only Ferno parts and Ferno-approved service on the stretcher.**

**⚠ WARNING**  
**Modifying the stretcher can cause injury and damage. Use the stretcher only as designed by Ferno.**

### 8.2 Parts List

No.	Part	Description	Qty
1	190-2031	Backrest (standard, all models)	1
2	190-2025	Backrest release lever (all models)	1
3	190-2024	Backrest gas spring (all models)	1
4	090-5914	Backrest airway-management frame (all models)	1
5	190-2033	Backrest section* for airway-mgmt. frame (all models) (airway frame not included)	1
6	090-5913	Backrest extending headrest (all models)	1
7	190-2032	Backrest section* for extending headrest (all models) (extending headrest not included)	1
8	190-2030	Footrest, stationary (RS2)	1
9	190-1365	Shock frame lever (all models)	pair
10	090-5940	Telescoping handle kit (RS2)	1
11	190-2026	Shock frame strap (all models)	1
12	090-5915	Footrest, pivoting (RS3, RS4)	1
13	190-2027	Sidearm, swing-down style (RS2, RS3)	1
14	190-2029	Guide wheel and hardware (all models)	1
15	190-2028	Side lift handles (all models)	set

**Note:** \*Backrests with optional frames are available separately. To obtain a complete backrest and extending headrest or airway-management frame, two kits are needed. For example, to obtain a backrest and airway-management frame, order kits #4 and #5.

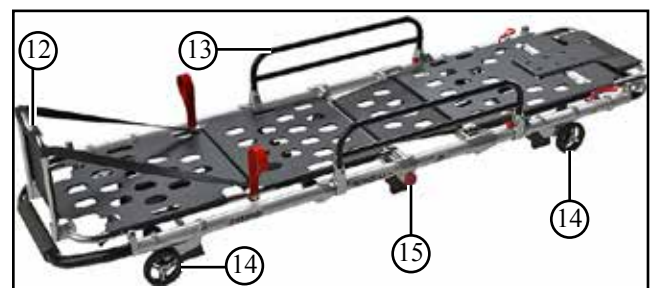
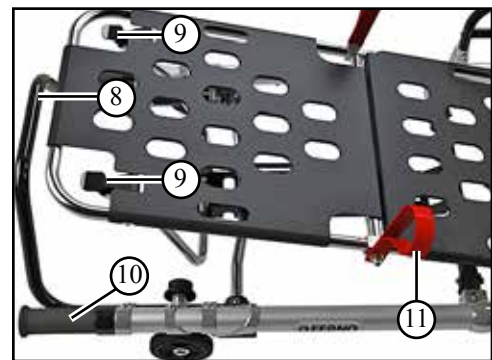
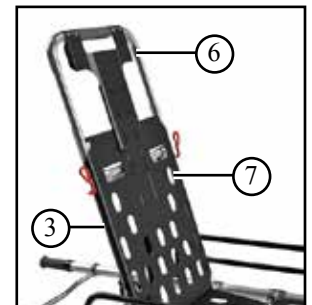
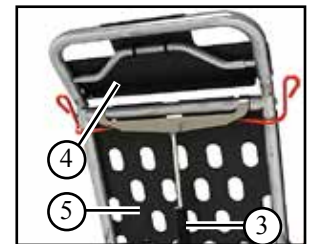
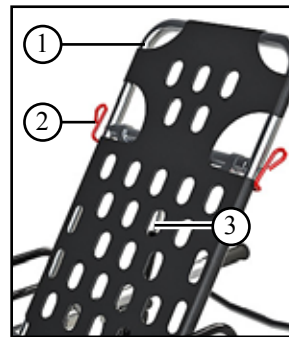

## 9 - ACCESSORIES

Ferno offers a full line of emergency medical service accessories (fasteners, IV poles, immobilizers, blankets, etc.). Follow all instructions packed with accessories. Keep the instructions with this manual. When using accessories, be aware of any special considerations such as doorway heights and widths, etc.

Contact Ferno Customer Relations (page 2) or your Ferno distributor for product information.



### WARNING

**Attaching improper items to the stretcher can cause injury. Use only Ferno-approved items on the stretcher.**

Description	Accessory
FL1 Fastening System	057-3080
Mondial® Safety Lock Device	083-2164
Mondial® Safety Lock Device (tube-type)	083-2189
Mondial® Tracker™	083-2165
PediMate®	031-3778
RS2, RS3, RS4 Mattress, bolstered	037-4874
RS2, RS3, RS4 Mattress, flat	037-4875
RS2, RS3, RS4 Storage tray	083-2166
RS2, RS3, RS4 DIN-pin kit (Germany)	083-2167
EFX or Mondial® IV pole	083-2024
IV Pole for Mondial® Monobloc MB64, MB70	083-2197
RS2, RS3, RS4 Restraint, Harness	031-3996
Restraint, Model 430 2-piece, 1.5m [5']	031-3892
Restraint, Model 430 1-piece, 2.1m [7']	031-3910











